

# Hydraulic Training Systems

Teaching and learning hydraulics in real-time



## MF500-HT-TSE Hydrostatic Transmission Training Simulator

### Purpose -

The MF500-HT-TSE is an instructor's "dream-come-true" with respect to teaching state-of-the-art, electronically-controlled hydrostatic transmission systems - hands-on.

It can even be driven as if it were on a construction site - in real-time. Driving a skid-steer loader around a construction site and operating the MF500-HT-TSE in the lab amounts to the same thing - without the hazards!

The electronically-controlled, infinitely variable, wheel-load system allows students to drive the hydrostatic transmission under any type of operating condition, i.e., up-hill, downhill, level surface - it can even simulate a runaway condition.

### Safety - the driving force behind the design and development of the MF500-HT-TSE -

Skid-steer type loaders are today's hydrostatic transmission training simulators - you will find one in the lab of almost every technical college in the country. However, these types of vehicles offer a host of unique safety hazards. Some of the more serious hazards include: unexpected vehicle motion, rotating wheels and shafts; noxious exhaust emissions; hot engine components; improperly supported vehicle, disconnecting of critical manufacturer installed safety devices, confined space, hot oil, etc.

The MF500-HT-TSE eliminates ALL of the hazards associated with using a skid-steer type loader as a hydrostatic transmission training simulator because it is designed for educators not for a construction site.

In addition to the numerous safety hazards posed by skid-steer type loaders in a lab, there are additional distinct disadvantages which include: the compactness of the vehicle makes it impossible for the instructor to engage in any type of demonstration or group activity with regard to component adjustment and or diagnostics procedures. It is also impossible to safely load the hydrostatic drive. These disadvantages erase 90% of the vehicle's educational value.



MF500-HT-TSE  
Hydrostatic  
Transmission  
Training Simulator

The MF500-HT-TSE is the solution fluid power instructors have been looking for because:

- It has the look and feel of a skid-steer type loader with outstanding teaching and learning capability.
- The hazards associated with using diesel-driven mobile machinery are eliminated.

• Instructors can perform meaningful group discussions and demonstrations associated with hydrostatic transmission pre-start, adjustment, and diagnostic procedures while the system is operating under any type of load conditions. The results are guaranteed: students will benefit because they are learning and understanding "need-to-know" information.

- Students can drive it, load it, troubleshoot it, and even "abuse" it, in the confines of a lab without ever putting rubber on the ground.

The MF500-HT-TSE is, without a doubt, the safest and most effective training simulator available for teaching and learning hydrostatic drives.



All FPTI™ simulators are available for operation at any voltage or frequency

# Hydraulic Training Systems

Teaching and learning hydraulics in real-time

## MF500-HT-TSE Hydrostatic Transmission Training Simulator

### Features and Benefits:

1. Teaching and Learning in real-time - Bridges the gap between simulated learning and real-world experience. Learning hydrostatic transmission systems on the MF500-HT-TSE more than adequately prepares students to meet the challenges associated with maintaining, servicing, repairing and troubleshooting hydrostatic transmission systems safely and effectively because they learn on a fully functional system.



MF500-HT-TSE shown with optional MF500-IS Implement & Steering System Training Module

2. The MF500 will rapidly transform students into much needed highly-skilled hydrostatic transmission technicians who have the skill-sets to safely and correctly perform the following:

- Pump and/or motor installation procedures
- Pump and/or motor pre-start checks and adjustments
- Pump and/or motor start-up checks and adjustments
- How to set charge pressure relief valves on systems with and without hot oil shuttle valves
- How to set main pressure relief valves and pressure override valves
- How to perform null adjustments on electronic displacement control valves
- How and where to check pump and motor case pressures
- How to perform mechanical adjustments on electronic and mechanical displacement control valves
- How to perform \*diagnostic procedures on a hydrostatic transmission system

\*for more information about the extent of the diagnostic procedures please refer to the troubleshooting section in the course workbook.

3. Extremely versatile -

Teach any type or make of hydrostatic transmission on the MF500-HT-TSE. The standard trainer is equipped with a dual tandem-pump configuration with dual joysticks and electronic pump displacement controls. You can purchase the MF500-HT-TSE with the hydrostatic transmission of your choice (prices may vary), or you can easily adapt a different type of pump at a later time.

The same applies to the wheel drive motors. The standard MF500-HT-TSE is equipped with dual high torque/low speed motors. However, it can also be equipped with low torque/high speed motors. Or a low speed/high torque motor can be installed on one side and a high speed/low torque motor on the other.

4. Nothing, including an actual vehicle, can match the MF500-HT-TSE's troubleshooting teaching and learning capability -

The perfect situation for a student to learn how to troubleshoot a hydrostatic transmission is to give them an actual machine, which is experiencing a real-time problem. There is a remote possibility that this can happen. However, what is virtually impossible is to find machines with every type of failure a typical hydrostatic transmission can experience so students can learn broad troubleshooting skills.



Dual tandem-pumps with dual joysticks and electronic pump displacement controls

**fluidpower**  
TRAINING SYSTEMS™  
fluidpowertrainingsystems.com  
A division of FPTI™

# Hydraulic Training Systems

Teaching and learning hydraulics in real-time

## MF500-HT-TSE Hydrostatic Transmission Training Simulator

5. Nothing else matches the MF500-HT-TSE's diagnostic learning capabilities -

Over three decades of hydrostatic transmission troubleshooting experience is designed into the MF500-HT-TSE. Its diagnostic capability is so advanced that every fault a typical hydrostatic transmission can experience in the field can be automatically introduced into the system for real-world troubleshooting in real-time. Faults include worn pump(s), worn motor(s), electronic problems, operation in one direction and not the other, sluggish operation, overheating, etc.

6. MF500-HT-TSE safety features are endless -

• No wheels on the ground equals no unforeseen safety hazards -

Tires and tracks on hydrostatically-propelled vehicles offer unique hazards in a confined space - even when they are elevated. Hydrostatic drives are extremely sensitive and on most machines can "drive-through" their park



brakes. The hazard level is heightened when a group of students are working on a machine with the engine running.

• No hazardous rotating wheels or moving tracks -

Rotating wheels and moving tracks present a variety of considerable safety hazards, which include: snagging clothing, crushing, etc. Every moving part on the MF500-HT-TSE was carefully analyzed for potential hazards. The four drive wheels are contained in heavy-duty, transparent plastic enclosures and all moving drive-train components are covered.

• No fatigue because all major components are mounted waist high -

Learning while crouched in the "belly" of a compact loader/excavator causes fatigue and frustration. It also results in students having to execute solo activities, which wastes valuable learning time. All hydraulic components on the MF500-HT-TSE are mounted where students work upright in a team-based learning environment.

• No slip hazards or environmental problems -  
To minimize oil spillage all hydraulic components are equipped with self-draining oil pans. Also, all quick-connect/disconnect connections are flat-face, zero-leak type.

• No confined space hazards -  
Learning a task is challenging enough without a student having to do it while standing on his/her head. Almost every hydraulic component in a compact mobile machine is extremely difficult to access, which makes team-based learning difficult or impossible. It also decreases retention. The lab is where students must learn and understand how to do the task safely and efficiently - and also generically. Once they know how, they will be able to deal with the access problems they will encounter in the field.

• Four (4) emergency stops -  
In the unlikely event that something goes wrong, every workstation has easy access to an emergency stop button - pump controls, hydraulic motors (left and right), implement directional control, and steering.

• Equipped with FPTI™'s exclusive Safe-T-Bleed® system -  
Safe-T-Bleed® is a product developed by FPTI™ and is exclusive to FPTI™ training simulators. The Safe-T-Bleed® system is designed to permit students to learn how to execute critical lockout and tagout procedures in accordance with State and Federal laws. Safe-T-Bleed® provides a means to safely bring a hydraulic system to zero mechanical state, which means no discharging high-pressure oil to atmosphere. Safe-T-Bleed® is also installed on the cylinders so students can learn how to purge air from cylinders without loosening connectors.

• Industry-standard lockout devices -  
All electrical panels and moving parts are equipped with industry-standard safety lockout/locking devices. The implement and steering mechanisms are equipped with self-contained mechanical locking devices identical to those found on actual machinery.

• Industry-standard Warning and Caution decals -  
Industry-standard, multi-lingual warning and caution decals are placed appropriately throughout the machine(s).





# Hydraulic Training Systems

Teaching and learning hydraulics in real-time

## MF500-HT-TSE Hydrostatic Transmission Training Simulator

### Specifications -

Prime mover: Electric motor; 20HP (15 kw); TEFC; C-face; 1800 RPM; 3-phase - 230/460V



Pumps: Dual, tandem-mount, axial piston type pumps; 138 bar (2000 PSI); 38 Lpm (10 GPM); electronic displacement control

Motors: Dual, high torque/low speed motors; fixed displacement 82 cm<sup>3</sup>/rev. (5.0 in<sup>3</sup>/rev.)



Reservoir capacity: 643 liters (170 gallons)

Dynamic wheel load: Independent left-hand and right-hand wheel drive with infinitely variable electronic load control in forward and reverse

Panel PC: Panel PC, Microsoft® Windows™ software; 48 cm (19") full-color touch-screen with pre-loaded learning software and diagnostic activities

Diagnostics: Pre-programmed activities covering every fault published in a typical hydrostatic transmission manufacturer's troubleshooting flow charts

### Safety features:

- Transparent wheel covers - Drive wheels enclosed in Lexan® enclosures
- Safe-T-Bleed® - Pumps equipped with Safe-T-Bleed® system for safe de-energization and verification
- Emergency stops - The MF500 has four (4) emergency stop switches
- Redundant electrical lockout - Both low voltage and high voltage enclosures are equipped with redundant lockouts



- Oil drip/re-circulating trays - Drip trays, which automatically recycle spilled oil in to the reservoir are located below both wheel motors and pumps
- Industry-standard Warning and Caution decals - Multi-lingual warning and caution decals are placed wherever necessary on the machine

### Options:

Prime mover: Diesel drive

Pumps: Any make or type currently available, e.g., Sauer Danfoss®, Rexroth®, Eaton®, Linde®, etc.

Pump controls: Mechanical, hydraulic pilot

Motors: High-speed/Low torque, fixed or variable displacement motors



# Hydraulic Training Systems

Teaching and learning hydraulics in real-time

## MF500-HT-TSE Hydrostatic Transmission Training Simulator

### Shipping Specifications -

Shipping weight (does not include optional MF500-IS-TSE Implement and Steering System training module, pallet or packaging):

789 kgs (1,740 lbs)

### Warranty -

FPTI™ warrants its products against defect in materials or workmanship for a period of two (2) years from date of delivery.

### Shipping dimensions:

188cm (74.0") tall x 163cm (64.0") wide x 193cm (76.0") long

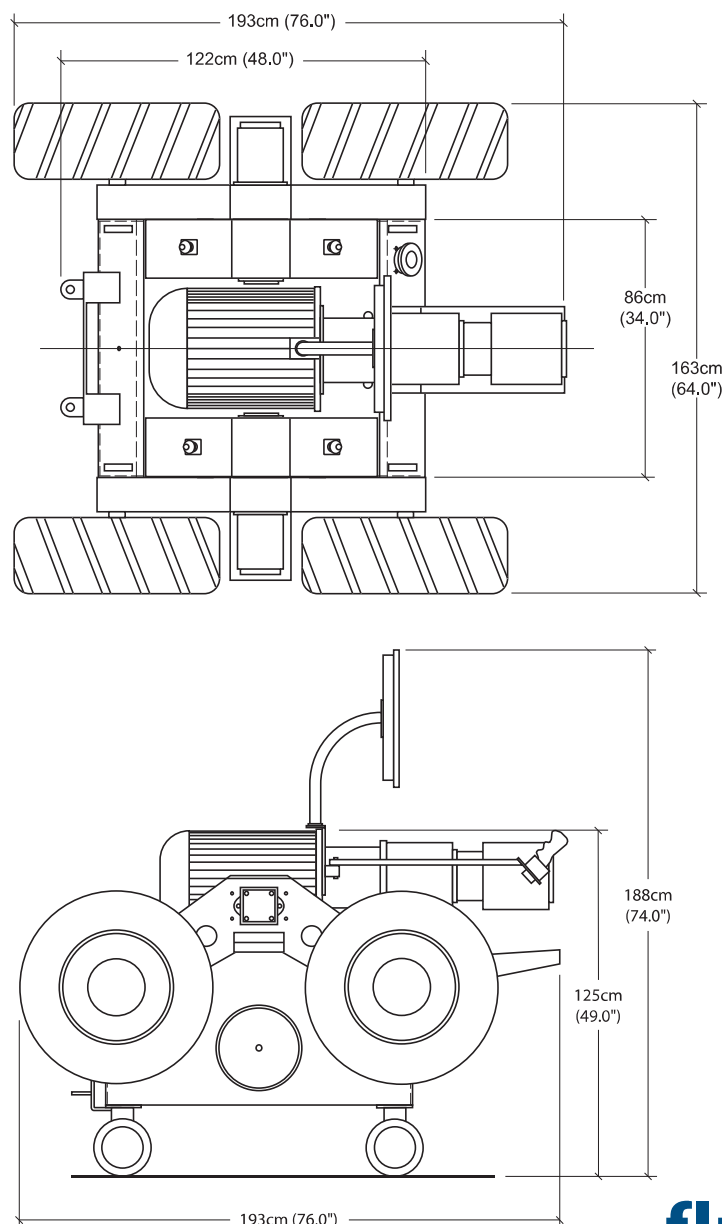

**fluidpower**  
TRAINING SYSTEMS™  
fluidpowertrainingsystems.com  
A division of FPTI™

# Hydraulic Training Systems

Teaching and learning hydraulics in real-time



## MF500-IS-TSE Hydraulic Implement and Articulated Steering System Module (optional)

Adding the optional, and affordable, “plug-and-play” hydraulic implement and articulated steering system trainer to the MF500-HT-TSE hydrostatic transmission trainer transforms it into a fully-functional front-end loader with articulated hydraulic steering, and a cylinder service center.

### Purpose -

Instructors who use actual front-end loaders for teaching bucket control hydraulic systems and hydraulic steering systems encounter the same problems as they do using a skid-steer type loader for teaching hydrostatic transmission systems - inherent safety hazards and the inability to safely load the bucket control and steering systems. Which arguably makes these types of vehicles useless for the purpose of technical education.

The MF500-IS-TSE hydraulic implement and articulated steering module is designed exclusively for educational purposes, which made safety our number one design objective.

### Safety -

The MF500 designers identified four potential hazards associated with the use of front-end loaders in an educational setting:

1. Bucket riding - It is possible for a student to ride in the bucket of a front-end loader.
2. Foot pinch-point - It is possible for the bucket of a front-end loader to be inadvertently lowered onto a student's foot. This problem is of particular concern if the bucket is equipped with a float option. The float option makes it possible for the bucket to free-fall to the ground from any elevation if the float position is inadvertently selected.
3. Unsecured load - If a student placed an object in the bucket of a front-end loader to simulate load there is a possibility the load could fall out if the bucket is inadvertently tipped forward.
4. Lift arm and rollback mechanical locks - Most bucket mechanisms have integrated mechanical locking devices. However, some lock the cylinder rods only. In the event of a cylinder being removed it is possible to compromise safety.

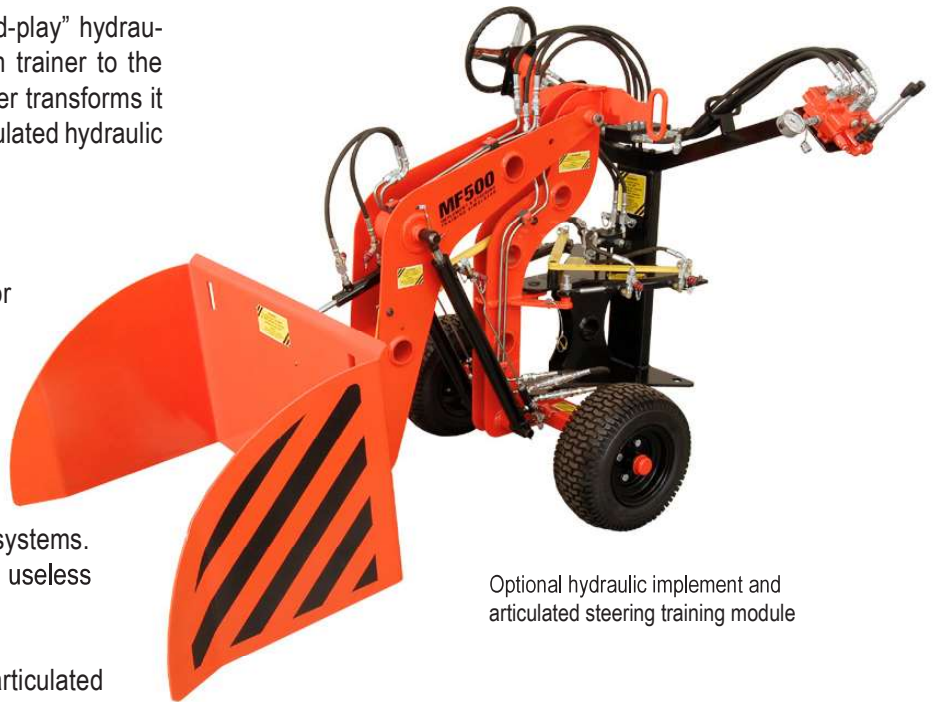

Optional hydraulic implement and articulated steering training module

The MF500 designers eliminated these hazards:

1. No floor surface in the bucket - Without a floor surface to stand on, students are not enticed into “riding” the bucket.
2. Bucket lip and sides do not touch the ground - The entire lower surface of the bucket is designed to stop at least 15cm (6”) off the ground to prevent foot crush hazards.
3. Safe and secure load - No floor means no loose loads, which can fall out accidentally. The load fastens securely to the bucket with redundant safety locks and pins.
4. Mechanical locks - The lift/lower, rollback/dump, and articulated steering mechanisms, are void of pinch-points. However, to give students a sense of reality, safety locking mechanisms identical to those used in industry were added so they can practice and learn how important mechanical locks are and how to properly use them.

In addition, the lift-cylinders are equipped with integral, non-adjustable, safety flow control orifices, which are designed to regulate descent velocity in the event of a hydraulic hose failure and when lowering a loaded bucket.



# Hydraulic Training Systems

Teaching and learning hydraulics in real-time

## MF500-IS-TSE Hydraulic Implement and Articulated Steering System Module (optional)

### Features and Benefits:

Load is mobile, safe, and environmentally friendly - The load consists of a 265 liter (70 gallon) water tank, which is contained on a mobile fixture. Heavy-duty casters with four-wheel brakes support the load.

Load engagement in the bucket is simple, safe, and semi-automatic. The load assembly has two steel arms welded to a steel support bar. When the load is rolled into the bucket the arms engage two slots (one on either side) in the rear plate of the bucket. Once through the slots, the arms are locked into place with pins (chained to the bucket).

If a student forgets to install the pin(s) a redundant locking system automatically locks onto the bucket as it begins upward movement.



Compact - Lab floor space is limited and expensive. The MF500-HT-TSE is designed with this in mind. With a footprint of only 163cm (64.0") wide x 193cm (76.0") long, it is a fraction of the size of an actual articulated machine, which makes it easy to maneuver and store.

The optional implement and articulated steering mechanism (MF500-IS-TSE) with a footprint of only 107cm (42.0") wide x 191cm (75.0") long sits on three wheels, which are positioned in the form of a tricycle making it easy to move and store.

Attaching or detaching the module is simple – wheel it into place, install two pins, connect two quick-connect fittings, plug in the 24VDC receptacle – and it's ready to go.

### Cylinder rebuild station -

As an added convenience the load mechanism is equipped with an integral cylinder rebuild station, which is designed to permit two groups of students to disassemble/assemble cylinders at the same time.

This feature enhances safety because without it students are forced to wrestle cylinders, which are either locked in a vice, or lying on a workbench. If the parts unexpectedly fall they can cause severe injuries to the legs and feet.



The MF500-IS-TSE ships with one (1) additional bucket lift/lower cylinder, which has defective seals. When teaching troubleshooting, the instructor can install the defective cylinder - no wrenches required.

The cylinder repair station is designed with safety in mind. The student simply slides the cylinder into a cradle (no tools necessary) and installs a locking pin, which not only secures the cylinder but also prevents it from rotating when the student is loosening/tightening the gland.

Even if the student forgets to install the locking pin, the cylinder cannot move even when the load lifts up. To prevent oil from spilling onto the ground, two (2) removeable oil drip trays are strategically located on the table top.

**fluidpower**  
TRAINING SYSTEMS™  
fluidpowertrainingsystems.com  
A division of FPTI™



# Hydraulic Training Systems

Teaching and learning hydraulics in real-time

## MF500-IS-TSE Hydraulic Implement and Articulated Steering System Module (optional)

### Specifications -

Pump: Gear type - 12.61 cm<sup>3</sup>/rev. (0.77 in<sup>3</sup>/rev.) fixed displacement

Pressure: 138 bar (2000 PSI) maximum pressure

Directional control valve: Sectional type (four sections) - inlet section, two spool sections, and outlet section.  
Section 1 - Inlet section with integral, adjustable pressure relief valve (cartridge-type)  
Section 2 - Three-position, four-way, cylinder spool configuration, load check valves, cylinder port relief valve (cartridge-type) and anti-cavitation valve (cartridge-type)  
Section 3 - Three-position, four-way, cylinder spool configuration, load check valves, two cylinder port/anti-cavitation combination valves (cartridge-type)  
Section 4 - Outlet section with power-beyond capability

### Steering

Orbitrol valve: Closed-center

### Differential Pressure

Unloading valve: Cartridge-type

### Cross-port

Relief valves: Adjustable, cartridge-type

### Cylinders:

Dual lift/lower, double-acting single rod cylinder:  
Bore - 1.5" (3.81 cm)  
Rod - 1" (2.54 cm)  
Stroke - 19" (48.26 cm)  
Gland type - threaded  
Rollback/dump cylinder:  
Bore - 1.0" (2.54 cm)  
Rod - 5/8" (1.59 cm)  
Stroke - 4" (10 cm)  
Steering cylinders:  
Bore - 1.0" (2.54 cm)  
Rod - 5/8" (1.59 cm)  
Stroke - 6" (15.2 cm)

Accumulator: 0.95 Liter (1 quart). Bladder-type.

### Safety features:

- Self-contained mechanical lock - lift/lower mechanism
- Self-contained mechanical lock - rollback/dump mechanism
- Self-contained mechanical locks - steering mechanism
- Safe-T-Bleed® installed on all cylinder ports to facilitate safe de-energization and verification procedures and drip-free and safe air-bleeding procedures
- Industry-standard Warning and Caution decals - Multi-lingual warning and caution decals are placed wherever necessary on the machine
- Zero pinch-points

### Diagnostics:

Diagnostics on the implement system are in real-time because the implement system operates under actual working and load conditions.

Wear-type faults are designed into the pump, pressure relief valve, directional control valves, and cylinders. Directional control valve diagnostics includes precision leak detection using FPTI™'s exclusive pressure/leak test technology. Students learn to isolate leakage between a cylinder port cartridge valve and wear between the spool and bore.

### Options:

Pump: Pressure-compensated, variable volume  
Pressure-compensated, variable volume with load-sense

### Directional

Control Valve: Electro-hydraulic control  
Hydraulic pilot with joystick control -  
- Single-axis  
Load-sense

Cylinders: Internal magnet for position feedback

All FPTI™ simulators are available for operation at any voltage or frequency

**fluid power**  
**TRAINING SYSTEMS™**  
fluidpowertrainingsystems.com  
A division of FPTI™



# Hydraulic Training Systems

Teaching and learning hydraulics in real-time

## MF500-IS-TSE Hydraulic Implement and Articulated Steering System Module (optional)

### Shipping Specifications -

Shipping weight (does not include pallet or packaging):  
254 kgs (560 lbs)

### Shipping dimensions:

114cm (45.0") tall x 107cm (42.0") wide x 191cm (75.0") long

### Warranty -

FPTI™ warrants its products against defect in materials or workmanship for a period of two (2) years from date of delivery.

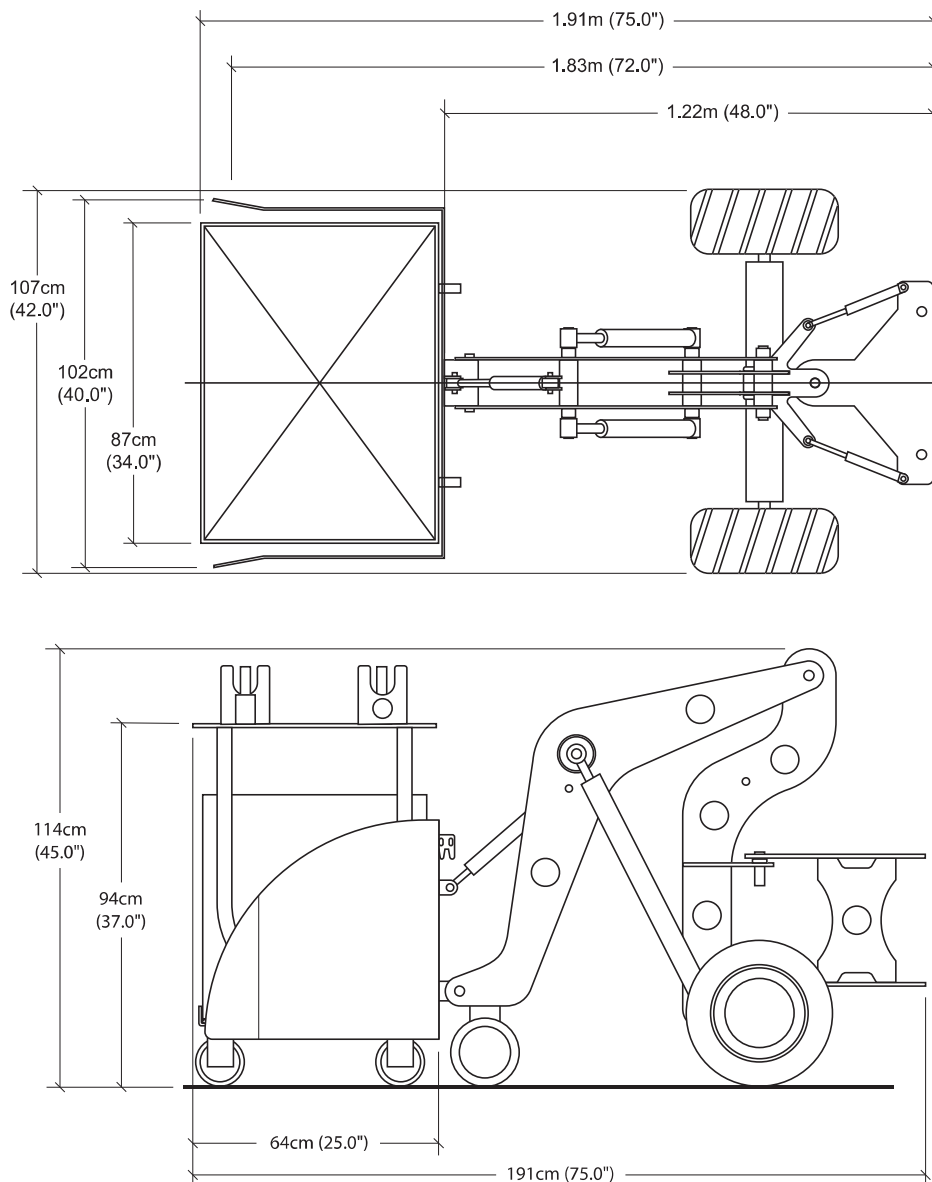

**fluidpower**  
TRAINING SYSTEMS™  
fluidpowertrainingsystems.com  
A division of FPTI™

